

**COMPONENTS**

- Material: Food approved high density polyethylene
- Standard Color: White (Other colors on request)
- Plastic Fingergrasp Handle
- Pour spouts available
- Gasket: EPDM (Ethylene Propylene Diene Monomer)

**WALL THICKNESS**

	cm	inch
• Pail	.170	.067
• Gasket Lid (654)	.183	.072
• Snap On Lid (624)	.155	.061
• Snap On Tear Tab Lid (623)	.155	.061

**STANDARD WEIGHT (+/- 2%)**

	g	lb.
• Pail (including handle)	651	1.43
• Gasket Lid (654) (includes gasket)	195	0.43
• Snap On Lid (624)	129	0.28
• Snap On Tear Tab Lid (623)	146	0.32

**THERMAL RESISTANCE** (Tested with water)

- Filling from -38°C (-36°F) to 82°C (180°F)
- Warehousing from -40°C (-40°F) to 39°C (102°F)

**TOP LOADING RESISTANCE**

	kg	lb.
• With Gasket Lid (654)	180	396
• With Snap On Lid (624)	112	246
• With Snap On Tear Tab Lid (623)	112	246

**CAPACITIES**

VOLUME	LITRES	GALLONS	
		IMP.	U.S.
Nominal	16.00	3.52	4.23
Maximum to Overflow	18.06	3.97	4.77
Maximum with Gasket Lid	17.31	3.81	4.57
Maximum with Snap On Lid	17.41	3.83	4.60
Maximum with Snap On TT Lid	17.46	3.84	4.61

Product Density g/cc	Maximum Weight Filled with Lid					
	GASKET LID		SNAP ON 624		SNAP ON TT 623	
	kg	lb	kg	lb	kg	lb
0.5	9.08	19.97	9.10	20.01	9.13	20.08
0.6	10.89	23.97	10.91	24.01	10.95	24.10
0.7	12.71	27.96	12.73	28.01	12.78	28.12
0.8	14.52	31.95	14.55	32.01	14.61	32.13
0.9	16.34	35.95	16.37	36.02	16.43	36.15
1.0	18.16	39.94	18.19	40.02	18.26	40.17
1.1	19.97	43.94	20.01	44.02	20.08	44.18
1.2	21.79	47.93	21.83	48.02	21.91	48.20
1.3	23.60	51.93	23.65	52.02	23.73	52.22
1.4	25.42	55.92	25.47	56.03	25.56	56.23
1.5	27.23	59.91	27.29	60.03	27.39	60.25

Above is a guideline only.  
Customer should verify with specific product to be packaged.

**LIGHTWEIGHT 16 LITRE CONTAINER**

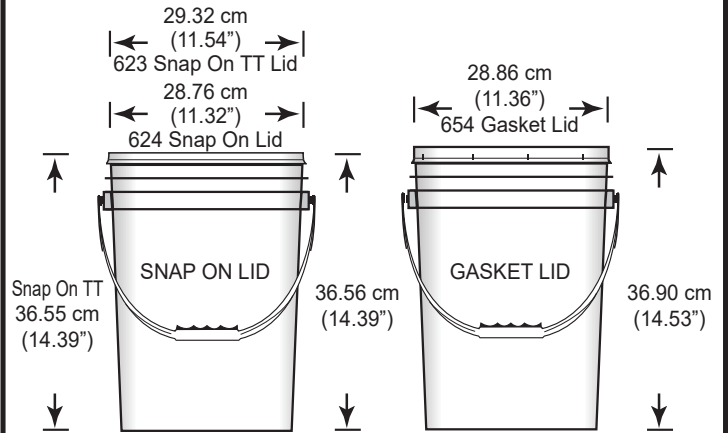

**NESTING**

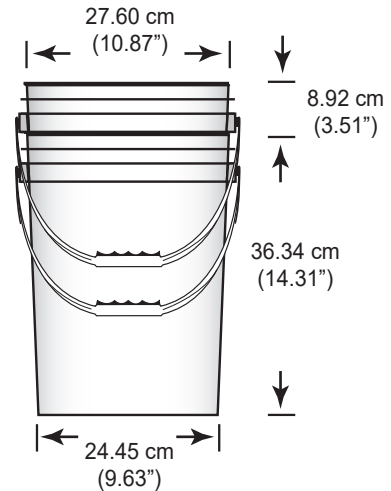

**STACKING**

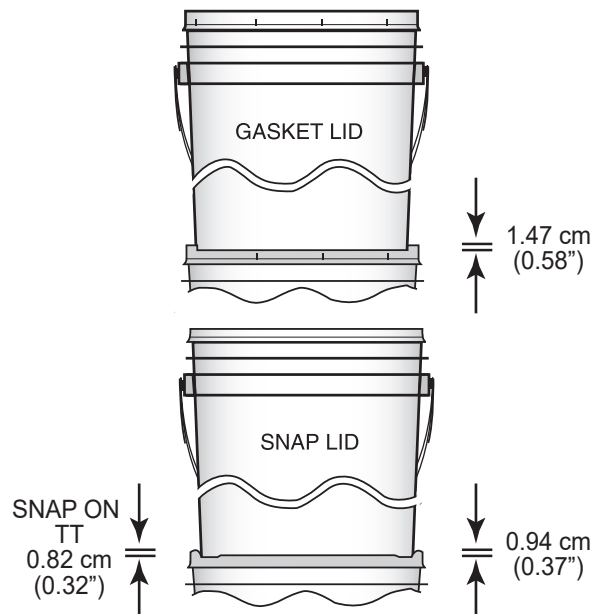

**PALLET UTILIZATION**

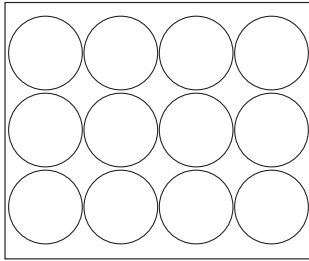

**122 cm x 102 cm**  
**(48" x 40")**

**IMPORTANT: Never let pails overlap edge of pallet**

**RECOMMENDED STACKING HEIGHT**

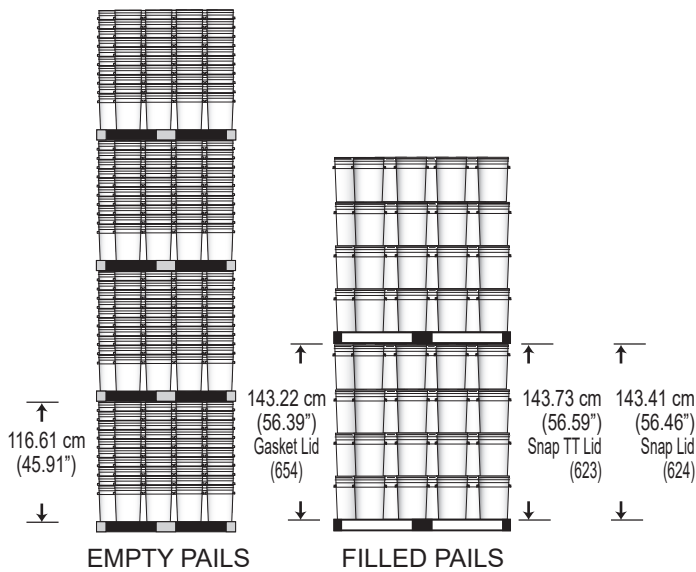

**OPENING**

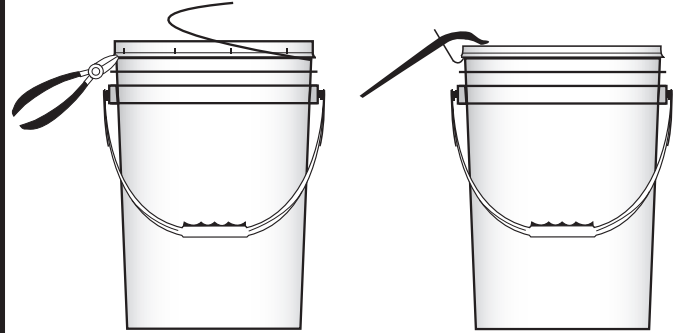

**Cutters**

**Lid lifter**

**CLOSING**

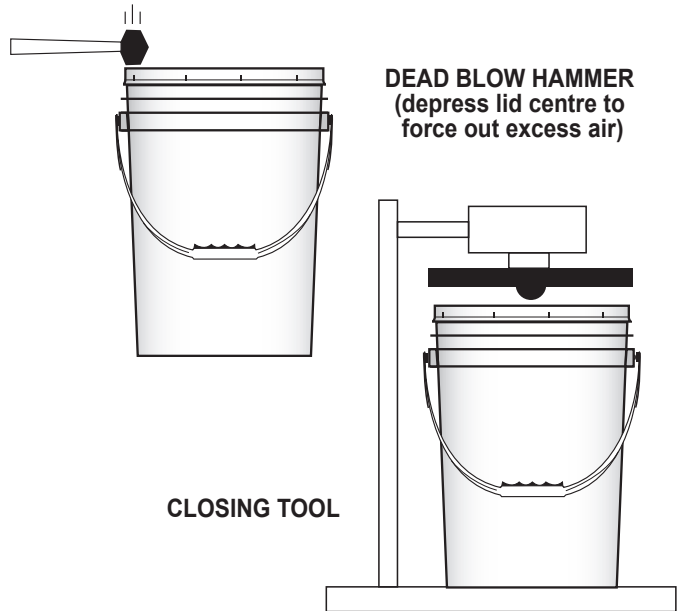

**DEAD BLOW HAMMER**  
(depress lid centre to force out excess air)

**CLOSING TOOL**

**PRINTING**

**DRY OFFSET PRINTING (UP TO MAXIMUM 4 PANTONE COLORS)**

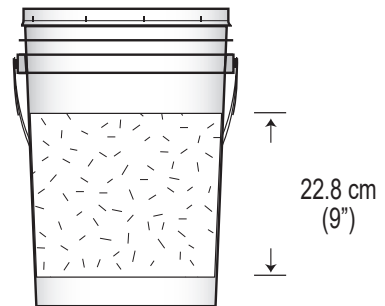

**SHIPPING DATA**

Quantity	732 PAIL		SNAP ON (624)		SNAP ON TT (623)		GASKET (654)	
	150/plt	100/box	600/plt	90/box	600/plt	50/box	300/plt	
Dimensions*	49.25" x 41.25" x 46.25"	25.75" x 13.00" x 22.50"	46.00" x 41.50" x 18.00"	25.75" x 13.00" x 22.50"	50.50" x 42.50" x 19.50"	25.75" x 13.00" x 20.25"	46.00" x 41.50" x 14.75"	
Volume	54.37 cu. ft.	4.36 cu. ft.	19.89 cu. ft.	4.36 cu. ft.	24.22 cu. ft.	3.92 cu. ft.	16.29 cu. ft.	
Weight**	100.25 kg 220.55 lbs	13.90 kg 30.58 lbs	78.90 kg 173.58 lbs	14.14 kg 31.11 lbs	89.60 kg 197.12 lbs	10.60 kg 23.32 lbs	60.00 kg 132.00 lbs	

\* AND \*\* DOES NOT INCLUDE WOODEN PALLET

**NOTE:** pallets are wrapped up in a protective stretch film.

**APPROVALS**

Pro-Western Plastics Ltd. disclaims any liability for the use of the information and data contained herein. We reserve the right to alter or modify any product and/or specification, at any time.